

# **Instruction Manual**

## **HK285A**

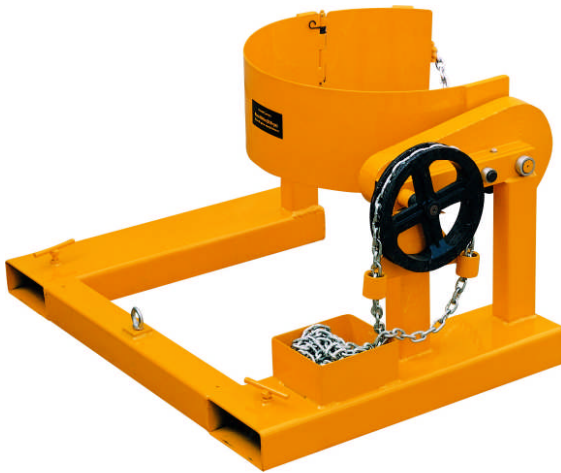

**Note: The Owner/Operator must read carefully and understand all the information presented here before operation.**

# Contents

Warnings and Safety Instructions .....	1
Receiving Instructions.....	2
Warranty .....	2
Operating Instructions .....	3
Warning Label Identification .....	4
Periodic Maintenance Instructions .....	4
Parts List .....	5
Location of Center of Gravity .....	9

## **WARNINGS & SAFETY INSTRUCTIONS**

Read owner's manual completely before operating unit!

- ~ Never operate drum carrier/rotator unless you are watching it.
- ~ Never use the drum carrier/rotator if the cradle is in need of repairs or in the case of a malfunction.
- ~ Do not stand below any part of a raised drum carrier/rotator or drum.
- ~ Never exceed the maximum loading capacity of the drum carrier/rotator as described below:

**Model HK285A:** 800 pounds for FULL drum, or 500 pounds for HALF-FULL drum.

- ~ Always load drum at the center of the cradle,
- ~ Consult factory for uneven loading.
- ~ When elevation is not required, always transport the drum in the lowered position.
- ~ Always transport drum only in vertical position when fork truck is moving.
- ~ Do not allow drum to impact on floor, ground, or dumping station etc., or there may be damage to the unit.
- ~ Remove drum before working on unit.
- ~ Consult factory if adding or performing any modification to the original equipment.
- ~ Use only maintenance parts supplied or approved by the manufacturer.
- ~ Make sure all operator safety labels are in place (p.2).

## **RECEIVING INSTRUCTIONS**

Every unit is thoroughly tested and inspected prior to shipment. However, it is possible that the unit may incur damage during transit. If damage is noticed when unloading, Please contact your supplier immediately.

## **WARRANTY**

This product is warranted for 90 DAYS from date of purchase to be free of manufacturing defects in material and workmanship.

The manufacturer's obligation hereunder is limited to repairing such products during' the warranty period, provided the product is sent prepaid back to the factory.

This warranty does not cover normal wear of parts or damage resulting from any of the following: negligent use or misuse of the product, use or application contrary to installation instructions, or disassembly, repair or alteration by any person prior to authorization from a factory representative.

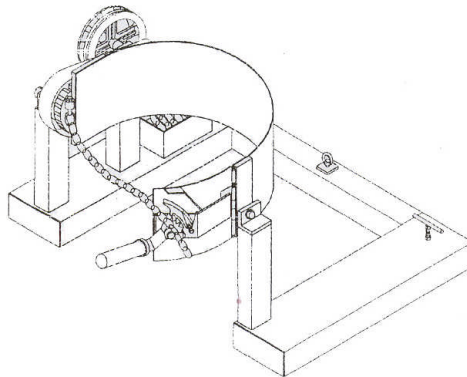

**DRUM CARRIER/ROTATOR**

## **Safety Instructions For The Operator**

1.) Please read all instructions THOROUGHLY before attempting to operate your new Drum Carrier/Rotator.

2.) **HK285A** has a MAXIMUM CAPACITY RATING of 800 pounds for FULL drum, and 500 pounds for FULL drum. Intended for lifting, moving, and pouring drums of size and type noted above.

DO NOT exceed these ratings as the unsafe condition that may result could cause damage or excessive wear, or make the unit awkward to handle.

3.) When operating, loading, unloading, or maintaining your drum carrier/rotator, always use care and good judgment, have good footing and a firm hold. Keep hands and loose clothing etc., away from all moving parts. Never allow anyone to be below any part of a raised Drum Carrier/Rotator or drum. Read operating instructions before operation.

## **Operating Instructions**

1.) Adjust the forks so that the inside width between the forks is 24 1/2" minimum. One fork must be locked to bed plate.

2.) Drive the truck forward to slip forks into fork sleeves. Attach safety chain to mast to secure drum carrier/rotator to forks.

3.) Open carrier cradle full width and hook cradle chain on stud.

4.) Drive truck with forks near- floor level to position carrier cradle around drum. Lock drum in place by clinching chain with ratchet.

5.) Remove control chain from box and place end of loop near operator's seat.

6.) Raise forks and transport drum in VERTICAL position.

7.) TO POUR DRUM: Pull on chain, rotating drum to angle required for emptying. For best control of drum pouring angle, pay out one side of the loop while pulling in the other.

8.) After emptying, rotate drum back to vertical position and drive the truck to deliver drum.

## Periodic Maintenance Instructions

1.) Lubricate gear-train once a month with a good grade lube. There are three grease fittings on the gear block for **HK285A**. Fitting in the idler bearing block.

2.) Oil cradle hinges, ratchet, pawl, chain and other moving parts periodically.

3.) Periodically inspect all moving parts, framework, and contact areas for signs of wear, fatigue or loosening. Tighten, adjust or replace parts as necessary to prevent failure and maintain proper functions.

## WARNING LABEL IDENTIFICATION

MAKE SURE ALL WARNING LABELS ARE IN PLACE!

1

**CAUTION**

DRUM MUST BE IN A VERTICAL POSITION WHEN MOVING

MODEL: HK285B

CAPACITY: 1,500 LBS.

**CAUTION**

DRUM MUST BE IN A VERTICAL POSITION WHEN MOVING

MODEL: HK285A

CAPACITY: 800 LBS.

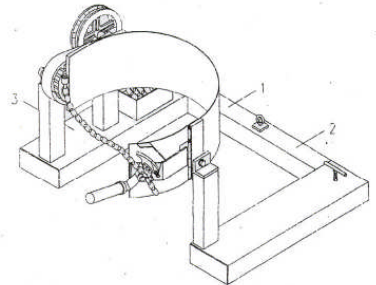

2

<b>CAUTION</b>	<b>PRECAUCION</b>	<b>PRUDENCE</b>
SAFETY CHAIN MUST BE FASTENED SECURELY TO FORKLIFT	LA CADENA DE SEGURIDAD DEBE DE SER AGARRADA CON SEGURIDAD A LA TRANSPALETA	LA CHAÎNE DE SÉCURITÉ DOIT ÊTRE BIEN ATTACHÉE AU MONTE-CHARGE

\*Product safety signs or labels should be periodically inspected and cleaned by the product users as necessary to maintain good legibility for safe viewing distance ... ANSI 535.4 (10.21) Contact manufacturer for replacement labels.

3

<b>CAUTION</b>	<b>PRECAUCION</b>	<b>PRUDENCE</b>
DRUM MUST BE IN VERTICAL POSITION WHEN MOVING	EL TAMBOR DEBE DE ESTAR EN LA POSICIÓN VERTICAL CUANDO EN MOVIMIENTO	LE BIDON DOIT ÊTRE EN POSITION VERTICALE LORS D'UN DÉPLACEMENT

# HK285A

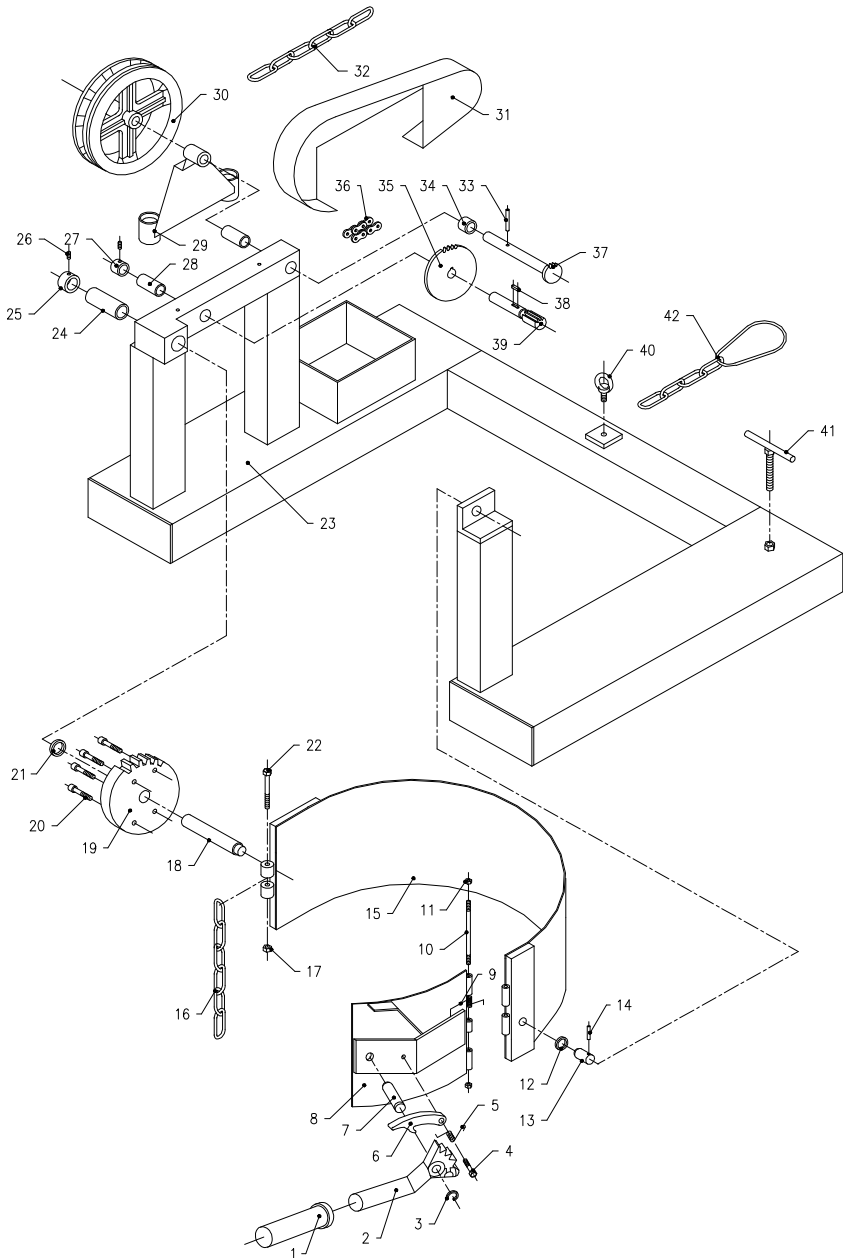

<b>No.</b>	<b>Description</b>	<b>Qty</b>	<b>No.</b>	<b>Description</b>	<b>Qty</b>
1	Rubber bushing	1	22	Hex bolt	1
2	Dentiform spanner	1	23	Pedestal ass.	1
3	Retaining ring	1	24	Bushing	1
4	Hex bolt	1	25	Aligning ring	1
5	Spring	1	26	Screw	2
6	Dentiform hook	1	27	Aligning ring	1
7	Pin	1	28	Bushing	2
8	Clamping ring	1	29	Chain rack	1
9	Spring	1	30	Chain wheel	1
10	Double-ended bolt	1	31	Chain cover	1
11	Nut	2	32	Galvanize chain	1
12	Ring	1	33	Spring pin	1
13	Pin	1	34	Ring	1
14	Spring pin	1	35	Big chain wheel	1
15	Hoop	1	36	Roller chain	1
16	Galvanize chain	1	37	Chain rod	1
17	Nut	1	38	Key	1
18	Pin	1	39	Gear axes	1
19	Big gear	1	40	Screw	1
20	Hex screw	4	41	Aligning bolt	2
21	Ring	1	42	Galvanize chain	1

## LOCATION OF CENTER OF GRAVITY

### MODEL HK285A

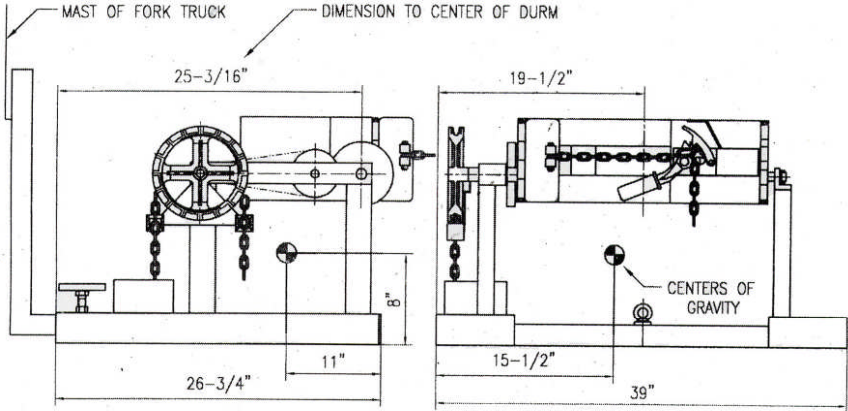

CAPACITY: 800 LBS.  
TOTAL 180 LBS. LOST LOAD  
FORK TUBES: 7-1/2" WIDE BY 2-1/2" HIGH

### MODEL HK285B

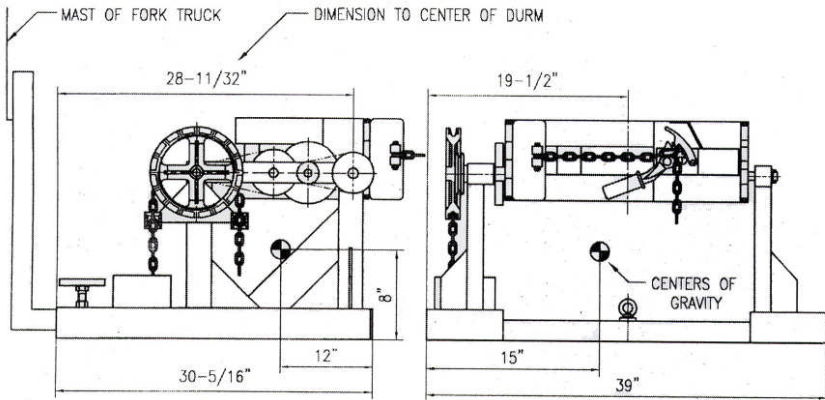

CAPACITY: 1500 LBS.  
TOTAL 225 LBS. LOST LOAD  
FORK TUBES: 7-1/2" WIDE BY 2-1/2" HIGH