

# Instruction Manual

## Vertical Drum Lifters/Dispensers



LM800



LG800

**Note:** The Owner/Operator must read carefully and understand all the information presented here before operation.

# Content

1.	Figure and Specification.....	2
1.1	Figure.....	2
1.1.1	Manual Type LM800.....	2
1.1.2	Geared Type LG800.....	3
1.2	Specification.....	3
2.	Part Name.....	4
3.	Warning.....	4
4.	Operation Instructions.....	4
5.	Exploded View & Part List.....	5
5.1	LM800.....	5
5.2	LG800.....	7

THANK YOU FOR USING THIS DRUM LIFTERS. FOR YOUR SAFETY AND CORRECT OPERATION, PLEASE CAREFULLY READ THIS INSTRUCTION BEFORE USING IT.

**NOTE:** All of the information reported herein is based on data available at the moment of printing. The factory reserves the right to modify its own products at any moment without notice and incurring in any sanction. So it is suggested to always verify possible updates.

## 1. FIGURE AND SPECIFICATION

### 1.1 Figure

#### 1.1.1 Manual Type LM800

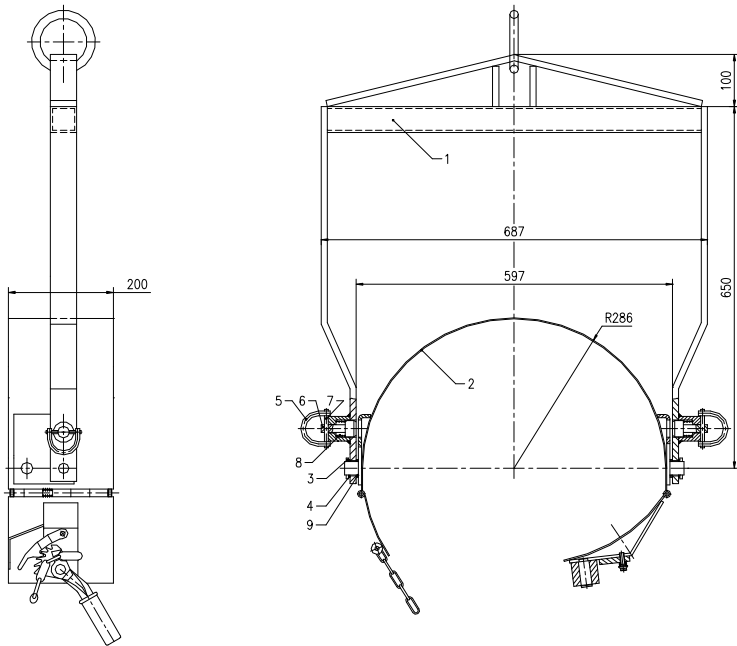

### 1.1.2 Geared Type LG800

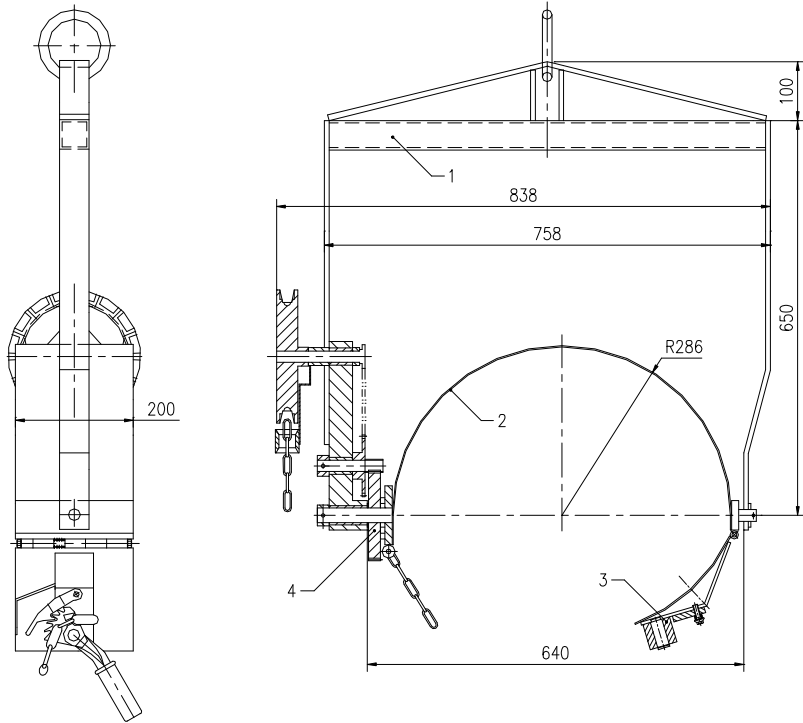

### 1.2 Specification

Model	Length (mm)	Width (mm)	High (mm)	Diameter (mm)	Net Weight (kg)	Capacity (lbs)
LM800	890	687	200	φ572	20	800
LG800	940	838	225	φ572	45	800

## **2. PART NAME**

- (1) Lifter frame
- (2) Hoop
- (3) Clamp
- (4) Rotator assembly
- (5) Geared driver assembly
- (6) Chain wheel

## **3. WARNING**

- (1) Do not overload this drum lifter beyond its rated capacity, drum must be clamped at the center position to avoid causing damage.
- (2) Do not stand under the drum lifter or when it is moving.
- (3) Do not operate when drum lifter go wrong.

## **4. OPERATING INSTRUCTIONS**

- 4.1 Enclose lifter to hook, and ensure it is installed accurately, hard and safety.
- 4.2 Hoop cling the drum closely at the horizontal position, buckle the chain on the geared spanner groove and turn spanner, the drum will be clamped and inspect it clamping hard.
- 4.3 Loosen the LM800 Hook when the drum is hung up, the drum can be turned in **90°** the drum will be clamped when loosen the replacement hook.
- 4.4 Loosen the spanner freewill when the drum is hung in the air, the drum can be turned through **360°**, when stopped it will be clamped in the freewheel angel.
- 4.5 Turn spanner with appropriate force at the clamped direction, while loosen the connecting of geared hook and geared spanner, if chain is unstuck, the drum can be taken out.

# 5. EXPLODED VIEW & PART LIST

## 5.1 LM800

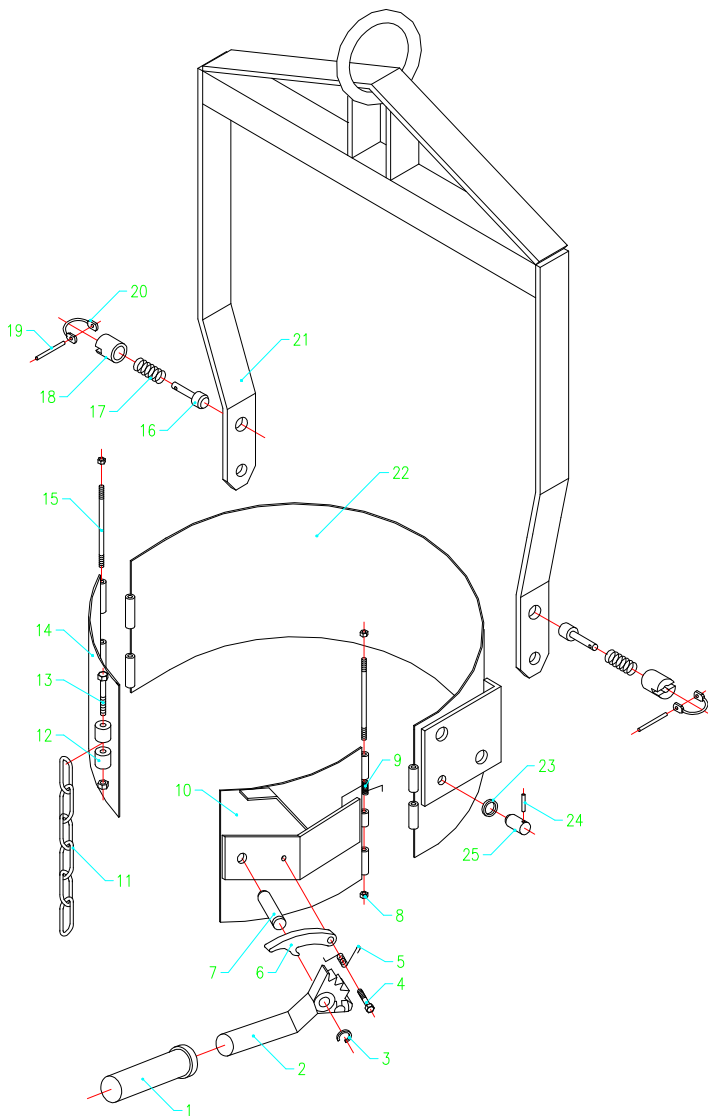

No.	Description	Qty	Size (mm)	Weight (kg)	Unit Price (USD)
1	Rubber Bushing	1		0.05	
2	Geared Spanner	1		1.05	
3	Retaining Ring	1	Φ20		
4	Hex Bolt	1	M8×30		
5	Torsional Spring	1			
6	Geared Hook	1		0.16	
7	Pin Axles	1	Φ20		
8	Hex Nut	2	M8		
9	Torsional Spring	1			
10	Clamping Board	1		1	
11	Chain	1		0.6	
12	Ring	2			
13	Hex Bolt	1	M8×60		
14	Connecting Board	1		0.63	
15	Double-head Bolt	2			
16	Sliding Pin	2			
17	Spring	2			
18	Bush	2			
19	Pin	2			
20	Handle	2			
21	Hoist Unit	1		10.7	
22	Hook Unit	1		5.26	

23	Separated Ring	2	$\Phi 5 \times 30$		
24	Spring Pin	2			
25	Pin Axles	2			

## 5.2 LG800

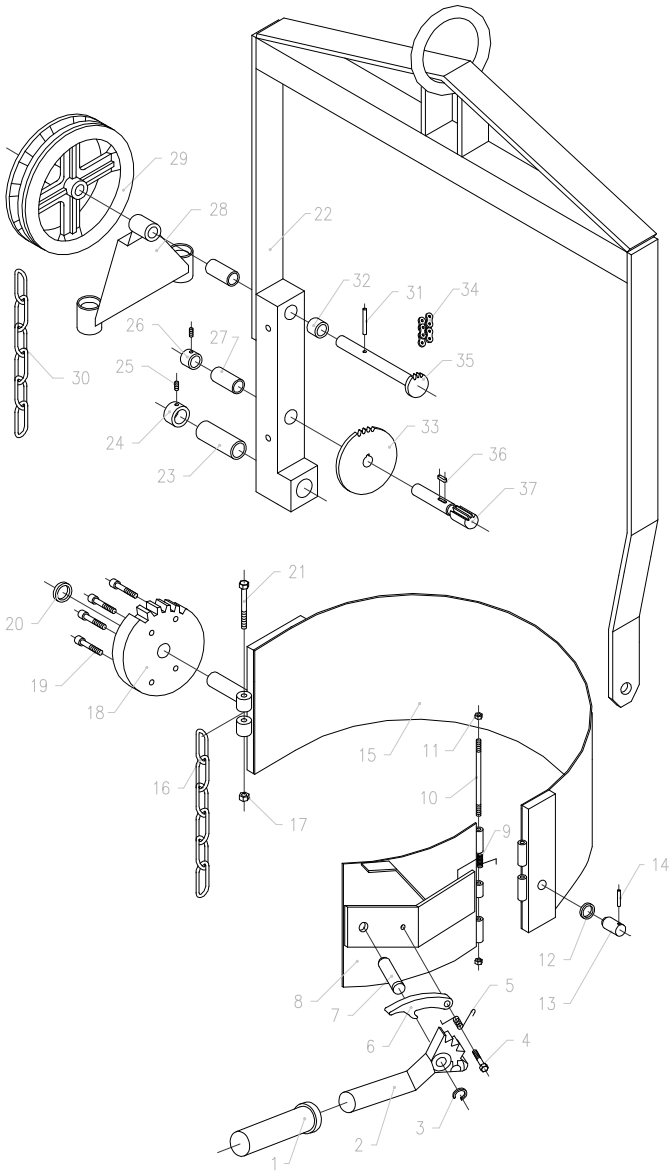

No.	Description	Qty	Size (mm)	Weight (kg)	Unit Price (USD)
1	Rubber Bushing	1		0.05	
2	Geared Spanner	1		1.05	
3	Retaining Ring	1	Φ20		
4	Hex Bolt	1	M8×30		
5	Torsional Spring	1			
6	Geared Hook	1		0.16	
7	Pin Axles	1			
8	Clamping Ring	1		1	
9	Torsional Spring	1			
10	Double-head Bolt	1			
11	Hex Nut	2	M8		
12	Separated Ring	1			
13	Pin Axles	1			
14	Spring Pin	1	Φ5×30		
15	Hoop Unit	1		6.5	
16	Chain	1		0.8	
17	Hex Nut	1	M8		
18	Big Gear	1		2.8	
19	Inner Hex Screw	4	M8×25		
20	Separated Ring	1			
21	Hex Screw	2	M8×60		

22	Hoist Unit	1		16	
23	Bush	1			
24	Aligning Ring	1			
25	Inner Hex Locking Screw	2	M6		
26	Aligning Ring	1			
27	Bush	2			
28	Chain Limiting Rack	1		0.8	
29	Chain Wheel	1		3.5	
30	Chain	1		3	
31	Spring Pin	1	$\Phi 5 \times 30$		
32	Separated Ring	1			
33	Chain Wheel	1		0.45	
34	Roller Chain	1			
35	Chain Wheel Axis	1		0.4	
36	Plane Key	1	$5 \times 5 \times 14$		
37	Geared Axis	1		0.3	